

User Manual



EVduty

EVC30 SERIES

ELECTRICAL VEHICLE
CHARGING STATION
LEVEL 2

Table of contents

Important safety instructions	3
Product	4
Models	5
Technical specifications	6
Installation	
Physical installation	7
Electrical installation	10
Smart-Home or Smart-Pro Module	
Initial configuration	11
Extended features	12
Operation sequence	
Immediate charging mode	16
Controlled access charging mode	16
Output current adjustment	18
Maintenance and cleaning	
Maintenance	21
Cleaning	21
Moving and storage	21
Troubleshooting	
Common problems	22
Diagnostic code	23
Contact us	25
Limited Warranty	26
<hr/>	
Figure list	
Figure 1: Portable model, Permanent Installation model, Output connector	4
Figure 2: Wall mount installation	7
Figure 3: Position of the unit vs the input power receptacle	8
Figure 4: Installation of padlock for anti-theft protection	9
Figure 5: Position of DIPSwitch (SW1, R4.10)	19
Figure 6: Position of DIPSwitch (SW5, R5.4+)	20
Table list	
Table 1: Connections inside junction box for permanent installation model	10
Table 2: Charging station state based on Main LED color	17
Table 3: Maximum output current vs circuit breaker value	18
Table 4: Maximum output current adjustment (SW1, R4.10)	19
Table 5: Maximum output current adjustment (SW5, R5.4+)	20
Table 6: Troubleshooting	22
Table 7: Diagnostic codes	24

IMPORTANT SAFETY INSTRUCTIONS



SAVE THESE INSTRUCTIONS

This manual contains important instructions for the EVduty EVC30 EV Charging Station that shall be followed during installation, operation and maintenance of the unit.

DEFINITIONS



This symbol represents a risk of electric shock



This symbol represents a warning

CAUTION

To reduce the risk of fire, connect only to a circuit provided with 40 amperes maximum branch circuit overcurrent protection in accordance with the National Electrical Code, ANSI/NFPA 70 and C.E.C Part 1 C22.1-12.

GROUNDING AND AC POWER CORD CONNECTION INSTRUCTIONS

This product must be grounded. If it should malfunction or break down, grounding provides a path of least resistance for electric current to reduce the risk of electric shock. This product is equipped with a cord having an equipment grounding conductor and a grounding plug. The plug must be plugged into an appropriate outlet that is properly installed and grounded in accordance with all local codes and ordinances.

WARNING

Improper connection of the equipment-grounding conductor is able to result in a risk of electric shock. Check with a qualified electrician or serviceman if you are in doubt as to whether the product is properly grounded. Do not modify the plug provided with the product—if it will not fit the outlet, have a proper outlet installed by a qualified electrician.

When using electric products, basic precautions should always be followed, including the following:

1. Read all the instructions before using this product.
2. This device should be supervised when used around children.
3. Do not put fingers into the electric vehicle connector.
4. Do not use this product if the flexible power cord or EV cable is frayed, has broken insulation, or any other signs of damage.
5. Do not use this product if the enclosure or the EV connector is broken, cracked, open, or shows any other indication of damage.
6. Do not use the product if the Main LED is lighting or flashing in **RED** or if the Main LED isn't working at all.
7. Servicing or maintenance shall be done while unit is de-energized.

Product

The EVduty EVC30 series is a Level 2 Electric Vehicle Charging Station. Its primary function is to send electrical power to an Electrical Vehicle that is equipped with the SAE J1772 Electric Vehicle connector. Here are the main parts of the product

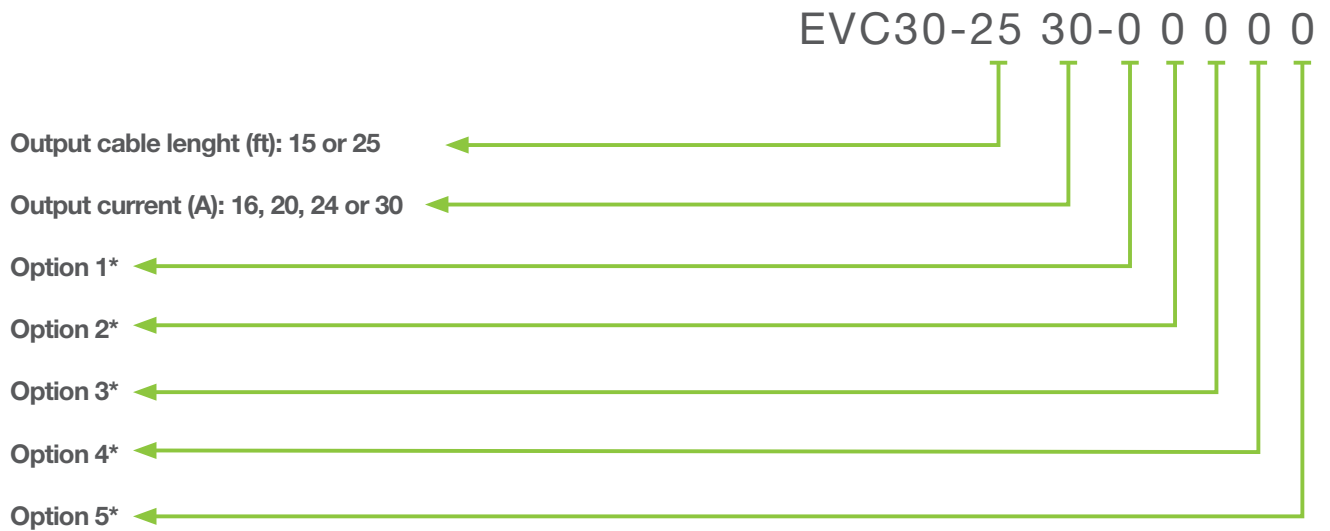

Figure 1: Portable model, Permanent Installation model, Output connector

- A** 240 V input connector (or wiring leads on some models)
- B** Main LED
- C** Enclosure
- D** Electric Vehicle Charging Cable
- E** SAE J1772 Connector's Release Button
- F** SAE J1772 Electric Vehicle Connector

Model

This charging station is offered in a variety of different models. The base options choices include length of the output cable and output current. There are also some other options: communication module, Power Input Type, Input Plug Type, etc. The part number of the unit is built as shown below:



Option 1: N/A (reserved for future, default as "0")

Option 2: N/A (reserved for future, default as "0")

Option 3: Communication module: 0 = None
1 = Smart-Home Module
2 = Smart-Pro Module

Option 4: Power Input Type: 0 = Plug
1 = Wiring leads

Option 5: Input Plug Type: 0 = NEMA 6-50P
1 = NEMA 14-50P
2 = None (only available if Option #4 is 1)

* Please contact the manufacturer for more details concerning these options.

Technical specifications

INPUT VOLTAGE

208-240 VAC single phase, 30 A

INPUT CONNECTOR

NEMA 6-50P

NEMA 14-50P (optional)

6' input cable with wiring leads (optional)

ENCLOSURE ENVIRONMENT RATING

UL/CSA NEMA types 3R.

PERSONAL PROTECTIONS

Ground Monitoring; Charge Circuit Interrupting Device with 20 mA threshold (CCID20)

DIMENSIONS (LENGTH X WIDTH X DEPTH)

330 mm x 165 mm x 60 mm (13,00" x 6,50" x 2,50")

OUTPUT CONNECTOR

SAE J1772, choice of 2 different output cable length: 4.6 m (15'), 7.5 m (25')

OPERATING TEMPERATURE

-40°C to 40°C

STORAGE TEMPERATURE

-40°C to 80°C

WEIGHT

4.5 kg (10 lbs)

PHYSICAL INSTALLATION

Portable model

This Electrical Vehicle Charging Station can be configured as a portable-type charger. Its design allow it to be installed in a non-permanent way on a wall by using the included wall mount bracket. Figure 2 illustrates the mounting of the unit to a wall.

The wall mount bracket must be installed on a wall and fixed on a vertical stud that can support at least 4 times the weight of the unit (so, able to support at least 18 kg (40 lbs)).

This device shall be mounted at a sufficient height from grade such that the height of the storage means for the coupling device is located between 600 mm (24 inches) and 1.2 m (4 feet) from grade.

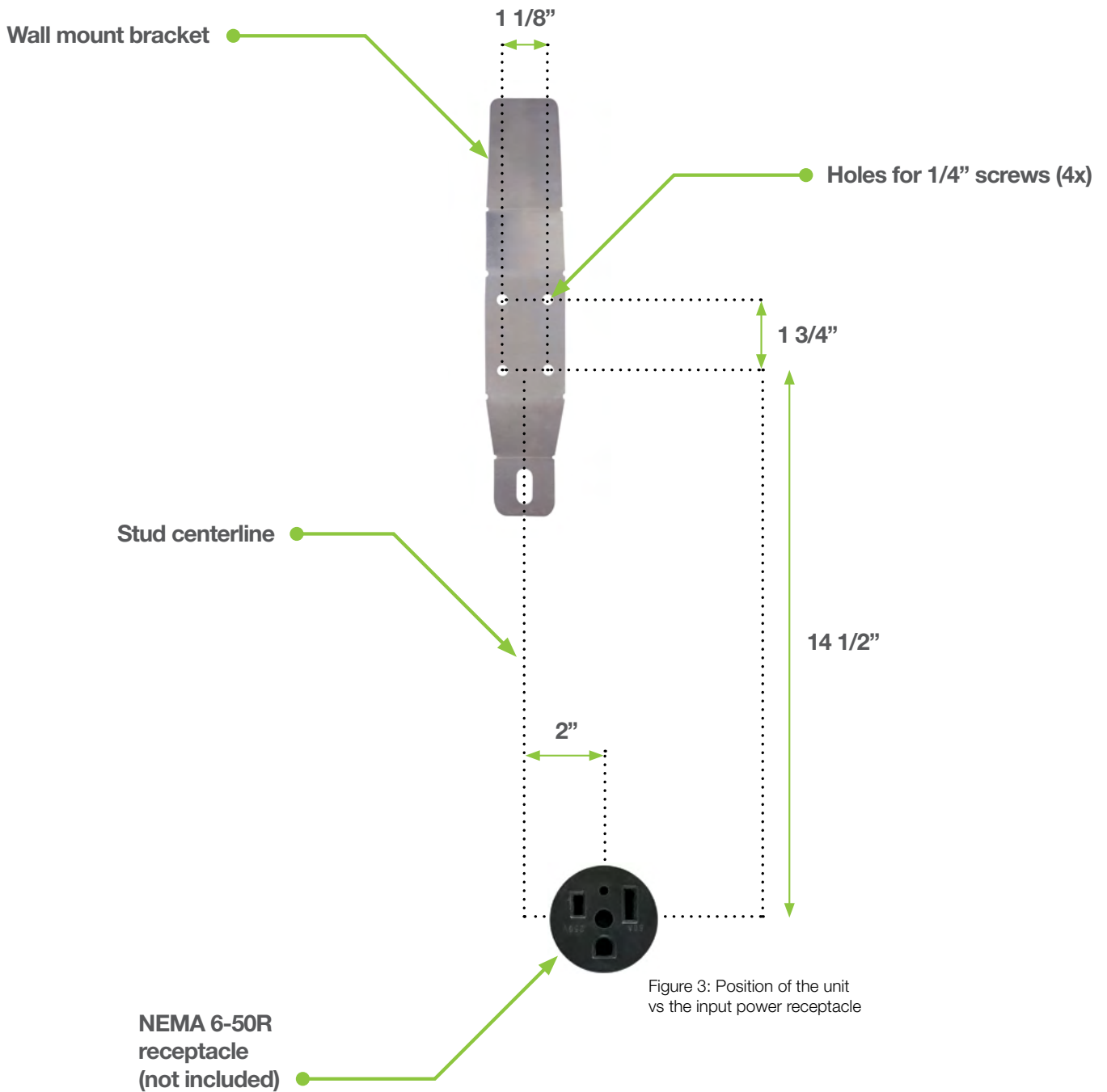

Figure 2: Wall mount installation

- A** Wall mount bracket
- B** Insert the unit on the wall mount bracket

Installation

Because the input power cable is quite short, the input power receptacle must be located correctly vs the position of the charging unit station. Figure 3 illustrates where the unit should be mounted for the input power cable to line up properly with the input power receptacle.



Permanent installation model

This Electrical Vehicle Charging Station can be configured for a permanent installation type of charger. The physical installation is nearly identical as the portable model (see Section [Installation/Physical Installation/Portable Model]), but require the unit to be locked on his wall mount bracket by installing a padlock in the hole as shown in Figure 4.



ELECTRICAL INSTALLATION



This equipment should be installed, adjusted, and serviced by qualified electrical personnel familiar with the construction and operation of this type of equipment and the hazards involved. Failure to observe this precaution could result in death or severe injury.



This Electrical Vehicle Charging Station requires a dedicated 40 A circuit breaker (it may require a lower value depending on the output current adjustment) in the main electrical panel.

IMPORTANT: The circuit breaker must be non-GFCI.

Portable model

1. Simply connect the input connector (NEMA 6-50P or NEMA 14-50P) into a suitable receptacle. (If the receptacle has to be installed, consult qualified electrical personnel.)
2. Once the unit is receiving power, the unit will do a self-test. During this test, the Main LED will light up **RED** (for a few seconds only). Once the test is complete and everything is in good shape, the Main LED will light up **GREEN**.

Permanent installation model

1. Route the input cable into a suitable junction box.



The size of the wiring used to feed this Electrical Vehicle Charging Station must be at least #8AWG. Wires used for input connection to the mains should have the required certification with suitable current carrying capability.

2. Do the connections as per the Table 1:

Table 1: Connections inside junction box for permanent installation model

DESCRIPTION	CABLE FROM MAIN ELECTRICAL PANEL	POWER INPUT CABLE FROM CHARGING STATION
Line 1	Black wire	Black wire
Line 2	Red wire	White wire
Neutral	White wire	N/A
Ground	Bare copper wire	Green wire

3. Put the circuit breaker at ON.
4. Once the unit is receiving power, the unit will do a self-test. During this test, the Main LED will light up **RED** (for a few seconds only). Once the test is complete and everything is in good shape, the Main LED will light up **GREEN**.

Smart-Home or Smart-Pro Module

A EVduty EVC30 charging station equipped with a Smart-Home or Smart-Pro Module require an initial configuration and offer extended features. This section describe the configuration procedure and the extended features.

INITIAL CONFIGURATION

Only a EVduty EVC30 charging station equipped with a Smart-Home/Pro Module requires an initial configuration. This configuration is necessary for the charging station to connect to the local Wi-Fi network and then be controlled by the EVduty mobile application. Please follow the following steps to complete the configuration:

1. Download and install the EVduty mobile app available on AppStore for iOS devices and on Google Play for Android devices.



2. Open the EVduty mobile app and create an EVduty account by following the instructions in the app. If you already have an EVduty account, log in by entering your username (email) and password
3. Make sure that the charging station is powered on and functional (**Main LED** is lit in **GREEN**).
4. Make sure that the charging station is at a reasonable distance from the source of the Wi-Fi signal to which the charging station should connect. (To check if this is the case, use a mobile device near the charging station and check that the Wi-Fi network is available and that the signal strength is sufficient).
5. In the EVduty mobile app, go to the "My terminals" tab.
6. Click on "Add a station".
7. Enter the information of the station (name of the station, address, description (optional), photo (optional)).
8. Click on "Add a terminal".
9. Click on "Open Wi-Fi Settings".
10. In the settings, connect to the Wi-Fi network emitted by the charging station that has a name of the type "EVduty-EVC30-XXXXX" where "XXXXX" represents the serial number of the charging station
11. Go back to the EVduty mobile app.
12. Enter the required information for the configuration:
 - Terminal's name
 - Wi-Fi network's name to which the charging station should connect
 - Wi-Fi network's password
 - Value of the protection circuit breaker (if different from 40 A)
 - Acces mode
 - » Datalogging: the charging station will offer an immediate charging mode.
Only the charge session data will be logged.
 - » Access control and datalogging: the charging station will offer a controlled access charging mode.
The charge session must be started using the EVduty mobile app
 - Nominal input voltage
13. Click on "Done". The configuration information will be sent to the charging station and a reset of the charging station will be performed. During this time, a clock icon will be displayed next to the terminal in the charging station in the EVduty mobile app.
14. The charging station will attempt to connect to the Wi-Fi network using the data provided during the configuration. If everything worked well, the charging station should be displayed in the "Available" state after about 45s

Smart-Home or Smart-Pro Module

EXTENDED FEATURES

Configure the charging station as “public” (Smart-Pro only)

The owner of a charging station equipped with a Smart-Pro Module can configure the charging station as a “public” one. A “public” charging station will be visible to all users of the EVduty mobile app.

To access this feature in the module app:

- Go to “My terminals” tab.
- In the Stations/Terminals list, click on the desired terminal.
- Go to “Details” tab.
- Activate “Public terminal” option.
- If wanted, activate “Paying terminal” option and modify the price and the associated price time.

Note: Please contact Elmec Customer Service to obtain a registration form in order to receive the generated revenues (fees may apply).

Display the current charging session

The owner of a charging station can display the current charging session (if there is a charging session in progress).

To access this feature in the mobile app:

- Go to “My terminals” tab.
- In the Stations/Terminals list, click on the desired terminal.
- Go to “Charge” tab.

Manage the access to the charging station

The owner of a charging station may restrict access to charging station (the charging station must be configured in “Access Mode” of type “Access control and datalogging”). This is done by sending SMS invitations. For a private charging station, the owner and the guests will be the only ones to have access to this charging station. For a public and paying charging station (Smart-Pro Module only), the owner and guests will have access to the charging station for free.

To access this feature in the mobile app:

- Go to “My terminals” tab.
- In the Stations/Terminals list, click on the desired terminal.
- Go to “Access” tab.
- Click on “Invite”.
- Send invitation(s) to the desired person(s) either from the Contacts list or from a phone number.
- An SMS will be sent to the guest and he will have the choice to accept it or not.

Smart-Home or Smart-Pro Module

Activity log

The owner of a charging station can consult the history of the activities that took place on his charging station. It can be the start/stop of a charging session, an error, etc.

To access this feature in the mobile app:

- Go to “My terminals” tab.
- In the Stations/Terminals list, click on the desired terminal.
- Go to “Activity” tab

Power Sharing (“Link”)

The owner of multiple EVduty EVC30 charging stations (all equipped with a Smart-Home or Smart-Pro Module) installed inside the same Station can configure them in Power Sharing mode. This Power Sharing configuration is named a “Link”. There may be several “Links” per Station.

This function allows a group of charging stations to share the available power according to the capacity of the protection circuit breaker that protects the power supply of the charging stations and the number of charging stations currently in use. This function has two levels that can be used separately or simultaneously.

“Level 1” is used when multiple charging stations are protected by a single circuit breaker whose capacity is between 20 A and 40 A. If more than one charging station is in use, the power delivered by each charging station will be reduced equally for all charging station currently in use so as not to trip the circuit breaker.

“Level 2” is used when multiple charging stations are individually protected by a circuit breaker whose capacity is between 20 A and 40 A and when all these circuit breakers are protected by a main circuit breaker whose capacity is between 40 A and 400 A.

Smart-Home or Smart-Pro Module

Examples of typical configuration

1. 2 charging station protected by a single 40 A circuit breaker.
(1x "Level 1" "Link" only)

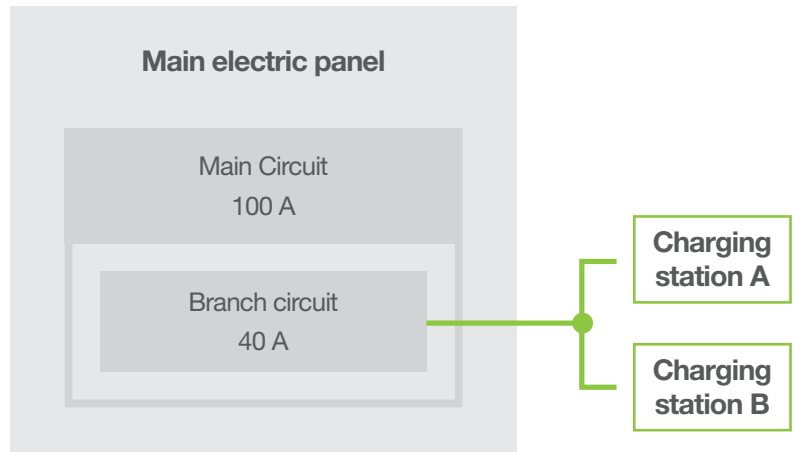

2. 4 charging stations individually protected by 40 A circuit breakers. These 4 circuit breakers are protected by a 100 A main breaker.
(1x "Level 2" "Link" only)

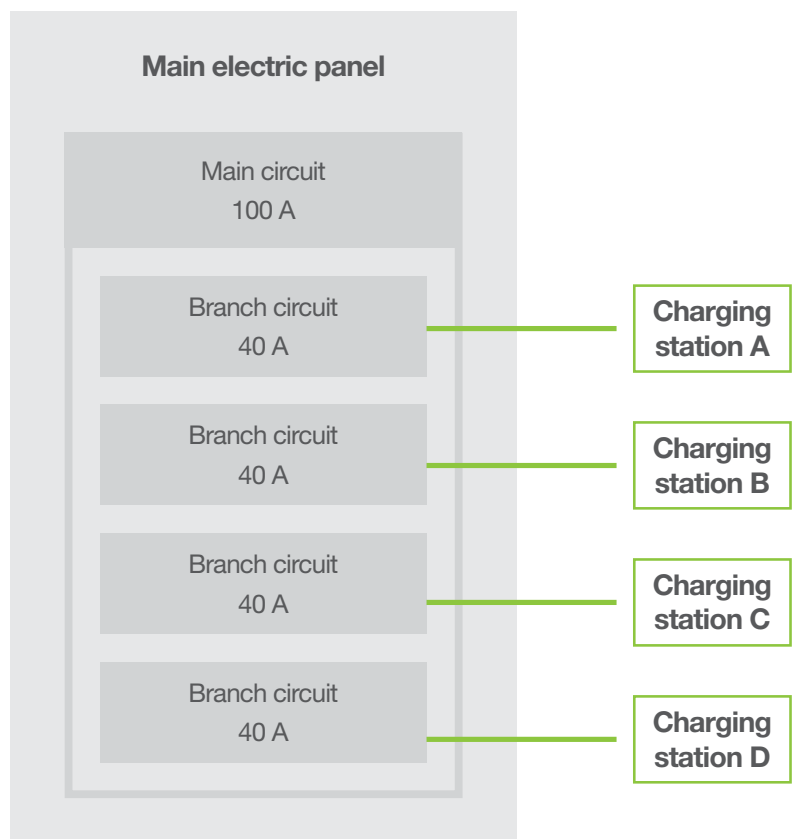

Smart-Home or Smart-Pro Module

4 pairs of charging stations.
Each pair of charging station is protected by a 40 A circuit breaker. These 4 circuit breakers are protected by a 125 A main breaker. (4x "Level 1" "Link" and 1x "Level 2" "Link")

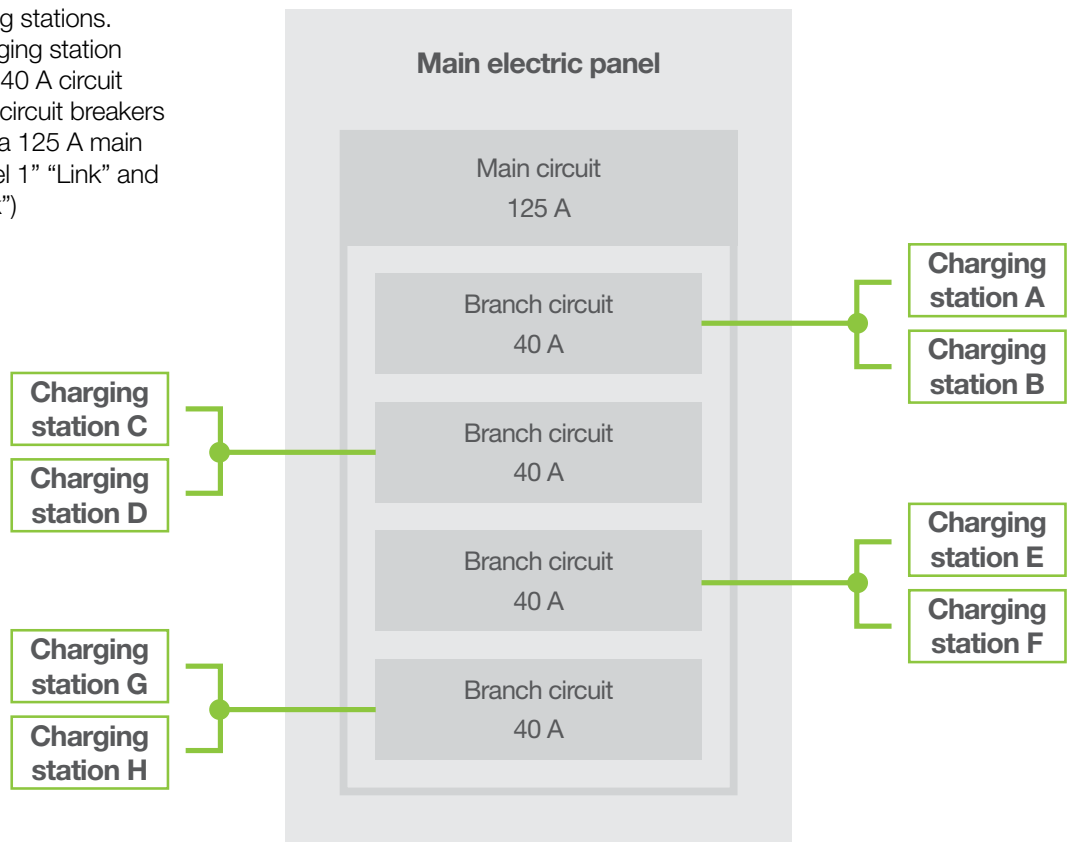

To access this feature in the mobile app:

- Go to "My terminals" tab.
- In the Stations/Terminals list, click on "Configure" on the desired Station.
- Click on "Terminals links".
- Create/add a "Link" by configuring the following parameters:
 - Link level
 - Value of the protection breaker
 - Select the charging stations to link
- Click on "Link" to validate the form.
- The charging stations in the "Link" will receive the configuration of the "Link" and will reset.

Operation sequence



Never operate the unit if the enclosure isn't sealed.

The Main LED located in the front of the unit (as seen in Figure 1) monitors the state of the unit. All models offer the immediate charging mode. Models that have the Smart-Home or Smart-Pro Module can offer the controlled access charging mode.

IMMEDIATE CHARGING MODE

1. Make sure that the unit has power (Main LED should be **GREEN**)
2. Using the Electrical Vehicle Charging Cable, connect the unit to the Electric Vehicle suitable SAE J1772 inlet connector.
3. Once connected, the Main LED should light up briefly **YELLOW** before going to **BLUE**.
4. The Main LED will stay lit in the **BLUE** color during the charging sequence.
5. The Main LED will light up **YELLOW** once the charge is complete.
6. When the charge is finished (or when the user wants to terminate the charge), simply disconnect the SAE J1772 connector from the Electric Vehicle by pressing the release button on the SAE J1772 connector.
7. Replace the Electric Vehicle Charging Cable on the supplied wall hook while making sure that the cable is coiled with a large enough radius to not damage the cable.

CONTROLLED ACCESS CHARGING MODE

1. Make sure that the unit has power (Main LED should be **GREEN**).
2. Using the Electrical Vehicle Charging Cable, connect the unit to the Electric Vehicle suitable SAE J1772 inlet connector.
3. Once connected, the Main LED should light up **YELLOW**.
4. Using a smart phone, open the EVduty mobile app (log in to your EVduty account if necessary).
5. Choose the Station where you are located. Then select the charging station with which you want to start a charging session.
6. Click on "Start". Charging should begin and a charging session screen should appear containing valuable information such as voltage, current, power, energy, cost and duration of the session.
7. The Main LED will stay lit in the **BLUE** color during the charging sequence.
8. The Main LED will light up **YELLOW** once the charge is complete.
9. If you want to stop the charging session, simply disconnect the SAE J1772 connector from the Electric Vehicle by pressing the release button on the SAE J1772 connector. You can also press the "Stop" button in the charging session screen in the EVduty mobile app.
10. Replace the Electric Vehicle Charging Cable on the supplied wall hook while making sure that the cable is coiled with a large enough radius to not damage the cable.

Operation sequence

Table 2 explains all the states of the unit depending on the color of the Main LED.

Table 2: Charging station state based on Main LED color

MAIN LED COLOR	CHARGING STATION ACTUAL STATE
Green	Unit is powered on and ready to charge a vehicle.
Flashing Green	Unit is powered on, but wasn't able to connect to the Wi-Fi network. It is possible to re-configure the unit from the EVduty mobile app (Smart-Home/Pro Module only)
Yellow	A vehicle is connected to the unite, but the charge is not allowed right now. Waiting for the vehicle to accept the charge.
	A vehicle is connected to the unit and the battery is fully charged.
Blue	A vehicle is connected and charging.
Flashing Blue	A vehicle is connected and charging and the maximum output current has been configured from the EVduty mobile app to a value lower than 30 A. The charging power is reduces. (Smart/Pro Module only)
	A vehicle is connected and charging in "Power Sharing" mode. The charging power is reduced. (Smart-Home/Pro Module only)
Red	Unit is in the initialization process.
Flashing Red	Please consult the Troubleshooting table.

Output current adjustment

The EVDuty EVC30 Series charging station offers the possibility to adjust the maximum output current. This adjustment may be necessary in the case where the charging station must be powered by a circuit which is protected by a circuit breaker of a value less than 40 A. Table 3 is used to determine the value of the maximum output current based on the value of the circuit breaker that protects the charging station.

Table 3: Maximum output current vs circuit breaker value

CIRCUIT BREAKER VALUE (A)	MAXIMUM OUTPUT CURRENT (A)
15	12
20	16
25	20
30	24
40	30

To adjust the maximum output current, perform the following steps:

1. Disable the electrical circuit that powers the charging station by setting the appropriate circuit breaker to « OFF » in the main electrical panel.
2. Disconnect the charging station's input power cable (either from the wall receptacle or from the junction box, depending on the model) and remove it from its wall-mount bracket.
3. Remove the six (6) screws holding the back plate to the charging station's enclosure.
4. Remove the back plate.
5. Using a small flat screwdriver, modify the state of the DIP Switch by moving the small white levers to the left or to the right according to the desired value. Please refer to Figure 5 and Figure 6 and also to Table 4 and Table 5 depending on the revision of the control circuit board installed in the unit.
6. Do the sequence of steps 1 to 4 in reverse for the reinstallation of the charging station.

Output current adjustment

Table 4: Maximum output current adjustment (SW1, R4.10)

CONTROL CIRCUIT BOARD REVISION 4.10 (SW1 COMPONENT)			
MAX OUTPUT CURRENT (A)	DIP SWITCH POSITION #1	DIP SWITCH POSITION #2	DIP SWITCH POSITION #3
16	Right	Right	N/A
20	Left	Right	N/A
24	Right	Left	N/A
30	Left	Left	N/A

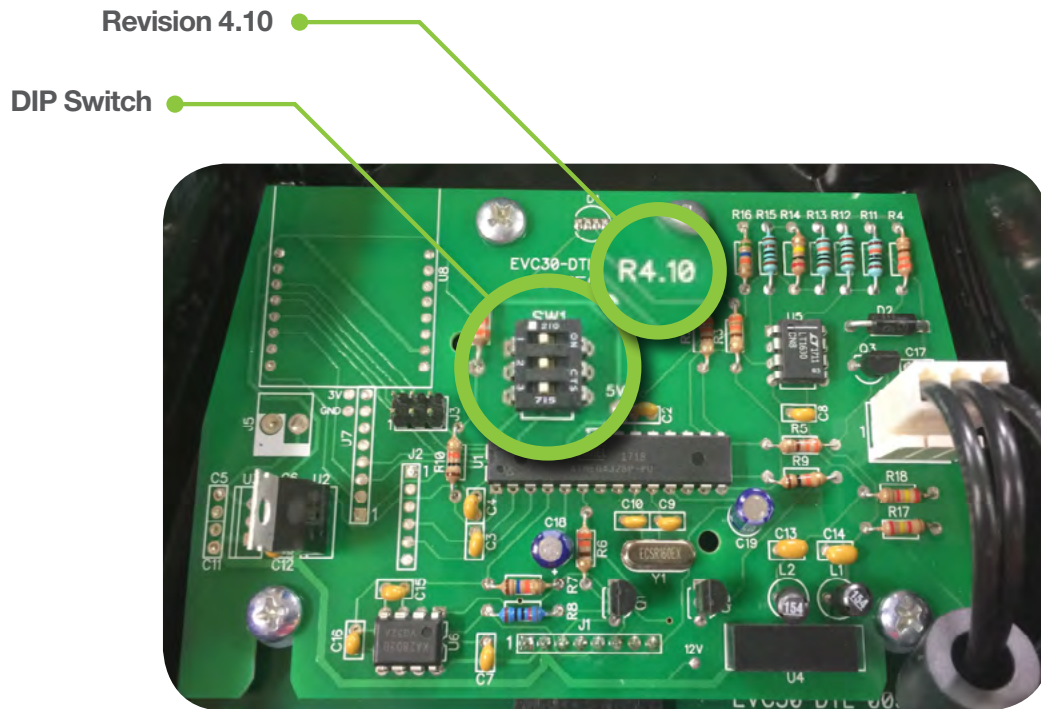

Figure 5: Position of DIPSwitch (SW1, R4.10)

Output current adjustment

Table 5: Maximum output current adjustment (SW5, R5.4+)

CONTROL CIRCUIT BOARD REVISION 5.4+ (SW5 COMPONENT)				
MAX OUTPUT CURRENT (A)	DIP SWITCH POSITION #1	DIP SWITCH POSITION #2	DIP SWITCH POSITION #3	DIP SWITCH POSITION #4
6	Right	Right	Right	N/A
8	Left	Right	Right	N/A
10	Right	Left	Right	N/A
12	Left	Left	Right	N/A
16	Right	Right	Left	N/A
20	Left	Right	Left	N/A
24	Right	Left	Left	N/A
30	Left	Left	Left	N/A

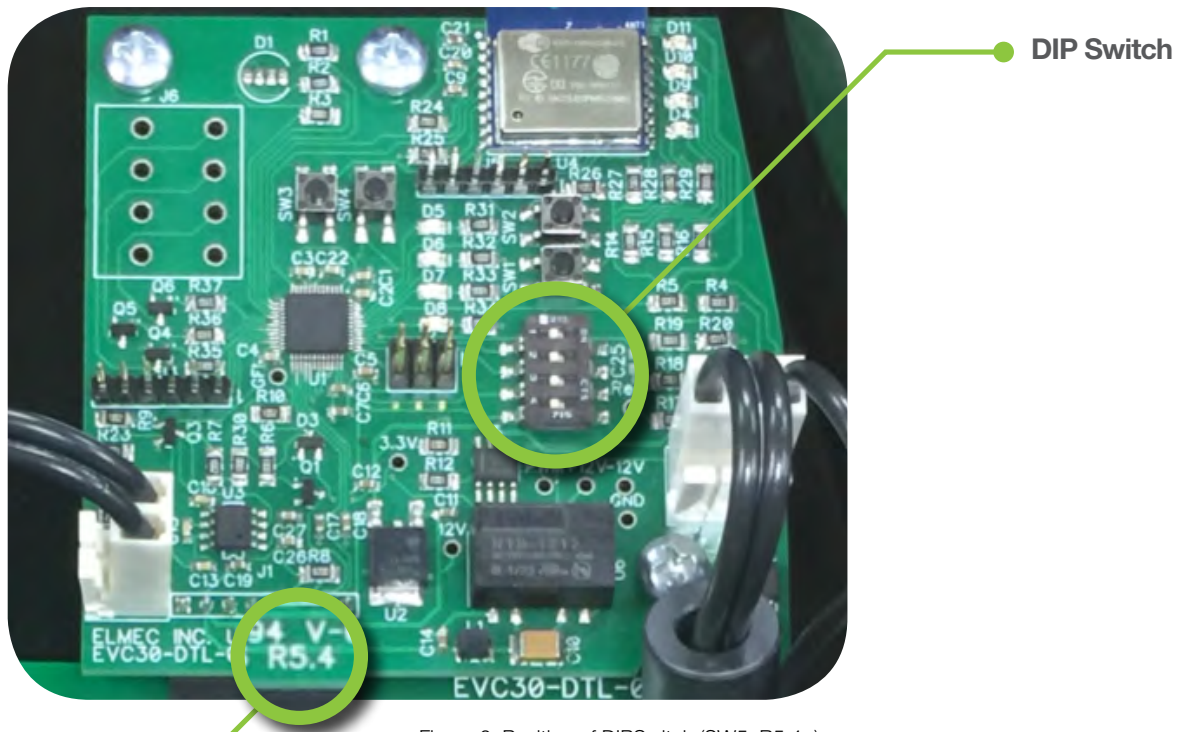

Figure 6: Position of DIPSwitch (SW5, R5.4+)

Révision 5.4+

Maintenance and cleaning

MAINTENANCE

This charging station does not require any major maintenance except a regular verification to be sure that there are no damages or excessive wear to the charging station itself or to any of the power cords/plugs/connectors.

CLEANING

The charging station and the power cords should be cleaned regularly. The cleaning process can be done using a wet rag. **Do not use water jet, high pressure washer, chemicals agents or solvents during the cleaning process. Do not splash water on the power cords or on the plugs/connectors.**

Moving and Storage

The portables models of the charging station must be stored in a clean and dry location and it must be located away from any high heat sources.

Avoid oily or corrosive substances to contact the charging station or the power cords and plugs/connectors between uses.

Avoid any fall or drop that can lead to impacts between a hard surface and the charging station. Keep any sharp object to be in contact with the charging station or the power cords or plugs/connectors.

To move the unit, unplug it from the wall outlet, then lift it vertically from its wall-mounted bracket. Do not lift or carry the unit by either the flexible input cord or the EV cable.

The unit has a non-operational storage temperature range of -40°C to +80°C (-40°F to +176°F).

COMMON PROBLEMS

Table 6 lists some of the common problems and their possible solutions.

Table 6: Troubleshooting

DIAGNOSTIC	PROBLEM	SOLUTIONS
The Main LED don't light up when the unit is powered ON.	The power to the unit is bad or absent.	Check if the dedicated circuit breaker is at the ON position.
		Check if the input cable is correctly connected into his receptacle.
	One or more fuses on the PCB are blown.	Appelez le Service de soutien du manufacturier.
The Main LED is flashing red.	The unit is in fault.	Consult Table: Diagnostic codes.
		Call the manufacturer support service.
The Main LED is going from blue to yellow rapidly.	The Electric Vehicle Charging Cable is worn, damaged or dirty.	Call the manufacturer support service.
The Main LED stays green after a connection with a vehicle.	The Electric Vehicle Charging Cable is worn, damaged or dirty.	The Electric Vehicle Charging Cable is worn, damaged or dirty.
The Main LED stays yellow after a connection with a vehicle.	The battery of the vehicle is full. No charging allowed.	N/A
	The Electric Vehicle Charging Cable is worn, damaged or dirty.	Call the manufacturer support service.

DIAGNOSTIC CODE

This charging station unit has a feature that displays a Diagnostic Code when the unit is in a known fault state. The way it works is that the Main LED will flash RED in a certain manner and the numbers of flashes are related to a 2-digit number. Here's an example:

Example with a diagnostic code #23:

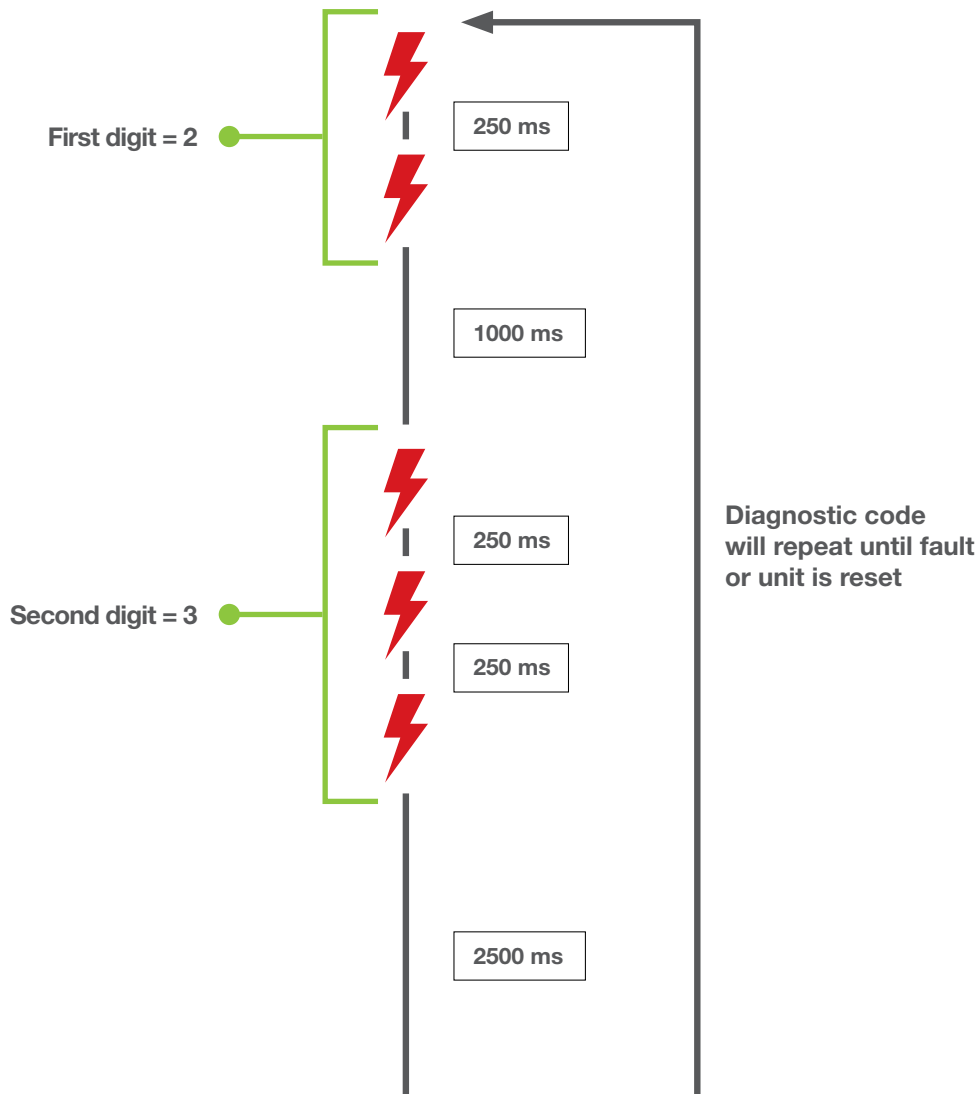

ms = millisecond

Troubleshooting

Table 7 lists the possible displayed Diagnostic Codes and the associated problems and solutions.

Table 7: Diagnostic codes

DIAGNOSTIC CODE	PROBLEM	SOLUTION(S)
11	At the initial self-test, the unit was missing a ground (GND) or one of the two AC lines (L1 or L2).	Check wiring from main electrical panel to the unit.
		Check if the input cable is correctly connected into his receptacle.
		Call the manufacturer support service.
12	At the initial self-test, the unit founds that the contacts of the relay are stuck or welded.	Call the manufacturer support service.
13	At the initial self-test, the unit wasn't able to correctly test the GFCI protection.	Call the manufacturer support service.
14	Problem with the internal microcontroller.	Call the manufacturer support service.
	Automatic internal firmware update in process.	Wait for the end of the automatic internal software update.
21	While charging, the unit trips on a ground fault. Unit will automatically reset after 15 mins for up to 3 retries.	Verify if output cable or connector is damaged.
22	While charging, the unit trips on a missing ground fault. Unit will automatically reset after 15 mins for up to 3 retries.	Same as Diagnostic Code #11.
23	While charging, the unit trips on a ground fault 3 consecutives times.	Same as Diagnostic Code #11.
24	While charging, the unit trips on a missing ground fault 3 consecutives times.	Same as Diagnostic Code #11.
31	Vehicle requires ventilation.	This charging station isn't compatible with this type of vehicle. Please do not attempt to charge this vehicle with this charging station.
32	Electrical problem in the vehicle charge port.	Bring the vehicle to the dealer for verification/ replacement of the vehicle charge port.
33	While initializing the charge session, the unit founds that the contacts of the relay are stuck or welded.	Call the manufacturer support service.
34	While initializing the charge session, the unit wasn't able to correctly test the GFCI protection.	Same as Diagnostic Code #13.
41	Immediately after the charge session begin, the unit trips on a ground fault.	Same as Diagnostic Code #21.
42	Immediately after the charge session begin, the unit trips on a missing ground fault.	Same as Diagnostic Code #11.
43	Invalid Pilot Signal.	Call the manufacturer support service.

Contact us



POSTAL ADDRESS

Service support Elmec
1141, 2^e Avenue, Shawinigan
(Québec) G9T 2X9



SERVICE SUPPORT

819 533-3888



FAX

819 533-3074



EMAIL

info@elmec.qc.ca



WEBSITE

elmec.ca

Limited Warranty

WHAT DOES THIS WARRANTY COVER?

This warranty covers any defects or malfunctions of your new EVduty EVC30 Electric Vehicle Charging Station.

HOW LONG DOES THE COVERAGE LAST?

This warranty runs for five (5) years from the purchase date for the whole unit excepting the “Electric Vehicle Charging Cable/Connector”. The “Electric Vehicle Charging Cable/Connector” is under warranty for three (3) years from the purchase date.

WHAT ELMEC WILL DO?

Elmec will repair any EVduty EVC30 Electric Vehicle Charging Station judged to have a defect or malfunction. In the event repair is not possible, Elmec will replace the EVduty EVC30 Electric Vehicle Charging Station with a new one of similar specifications and price.

WHAT DOES THIS WARRANTY NOT COVER?

Any defect caused by an abnormal use of the product.

HOW TO GET SERVICE?

To use this warranty, you must contact the Elmec Support Service and a qualified technician will verify if there is a real problem with your EVduty EVC30 Electric Vehicle Charging Station. If it's the case, send the EVduty EVC30 Electric Vehicle Charging Station postage paid with a purchase proof to the following address:

ELMEC SERVICE SUPPORT

1441, 2^e Avenue, Shawinigan
(Québec) G9T 2X9

Elmec will inspect the EVduty EVC30 Electric Vehicle Charging Station and contact you within 72 hours following the product reception to tell you if the product will be repaired or replaced

YOUR RIGHTS UNDER THE ACTUAL APPLICABLE LAW

This warranty gives you specific legal rights, and you may also have other rights which vary from a province to another.